



DW60

Four-wheel dumpers: payload > 5 t



The power house – wheel dumper DW60.

The wheel dumper has everything a key player needs: hydrostatic four-wheel drive, 2 types of skip, 6,000 kg payload and a powerful engine. And the modern safety cab turns it into an all-season dumper - all fitted ex-works.

- More power: DW60 Power model with an engine output of 86 kW
- 2 types of skip: Front-tipping skip (standard), swivel tipping skip (optional); up to 3,200 l skip capacity (heaped) as standard
- Supreme off-road capability thanks to a center-pivot angle of up to 29 degrees
- A top speed of 25km/h gets transport jobs done fast
- Optional cab available ex-works



Technical specifications

DW60

Operating data

| | |
|--|----------|
| Payload | 6,000 kg |
| Shipping weight Front tip skip ROPS | 4,483 kg |
| Shipping weight Front tip skip cabin | 4,683 kg |
| Shipping weight Swivel skip ROPS | 4,866 kg |
| Shipping weight Swivel skip cabin | 5,066 kg |
| Skip capacity Swivel skip, levelled | 2,350 l |
| Skip capacity Swivel skip, heaped | 3,200 l |
| Skip capacity Swivel skip, water level | 1,660 l |
| Skip capacity Front skip, levelled | 2,650 l |
| Skip capacity Front skip, heaped | 3,500 l |
| Skip capacity Front skip, water level | 1,900 l |

Engine / Motor

| | |
|---------------------------------------|-----------------------------------|
| Engine / Motor manufacturer | Perkins |
| Engine / Motor type | 854F |
| Engine / Motor | watercooled 4cylinder turbodiesel |
| Engine performance acc. to ISO 3046/1 | 55 kW |
| Displacement | 3,400 cm ³ |
| Engine RPM | 2,500 rpm |
| Emissions | Stage 3b / Tier 4 final |
| Traction drive | 4WD, hydrostatic |
| Travel speed | 25 km/h |
| Articulation angle | 29 ° |
| Pendulum angle | 11 ° |
| Tires | 405/70-20 |
| Steering pump | Axial piston pump |
| Flow rate | 152 l/min |
| Operating pressure | 150 bar |
| Duty pump | Gear pump |
| Operating pressure | 235 bar |
| Tank capacity | 82.5 l |



Hydraulic oil tank

55 l

DW60 Power

Engine / Motor

| | |
|-----------------------------|-----------------------------------|
| Engine / Motor manufacturer | Perkins |
| Engine / Motor type | 854E |
| Engine / Motor | watercooled 4cylinder turbodiesel |
| Engine performance | 86 kW |
| Displacement | 3,400 cm ³ |
| Engine RPM | 2,500 rpm |
| Emissions | Stage 3b / Tier 4 interim |

DW60 LRC

Engine / Motor

| | |
|-----------------------------|-----------------------------------|
| Engine / Motor manufacturer | Perkins |
| Engine / Motor type | 1104D |
| Engine / Motor | watercooled 4cylinder turbodiesel |
| Engine performance | 62.5 kW |
| Displacement | 4,400 cm ³ |
| Engine RPM | 2,400 rpm |
| Emissions | Stage 3a / Tier 3 |
| Tires | 400/55R22.5 |



Dimensions

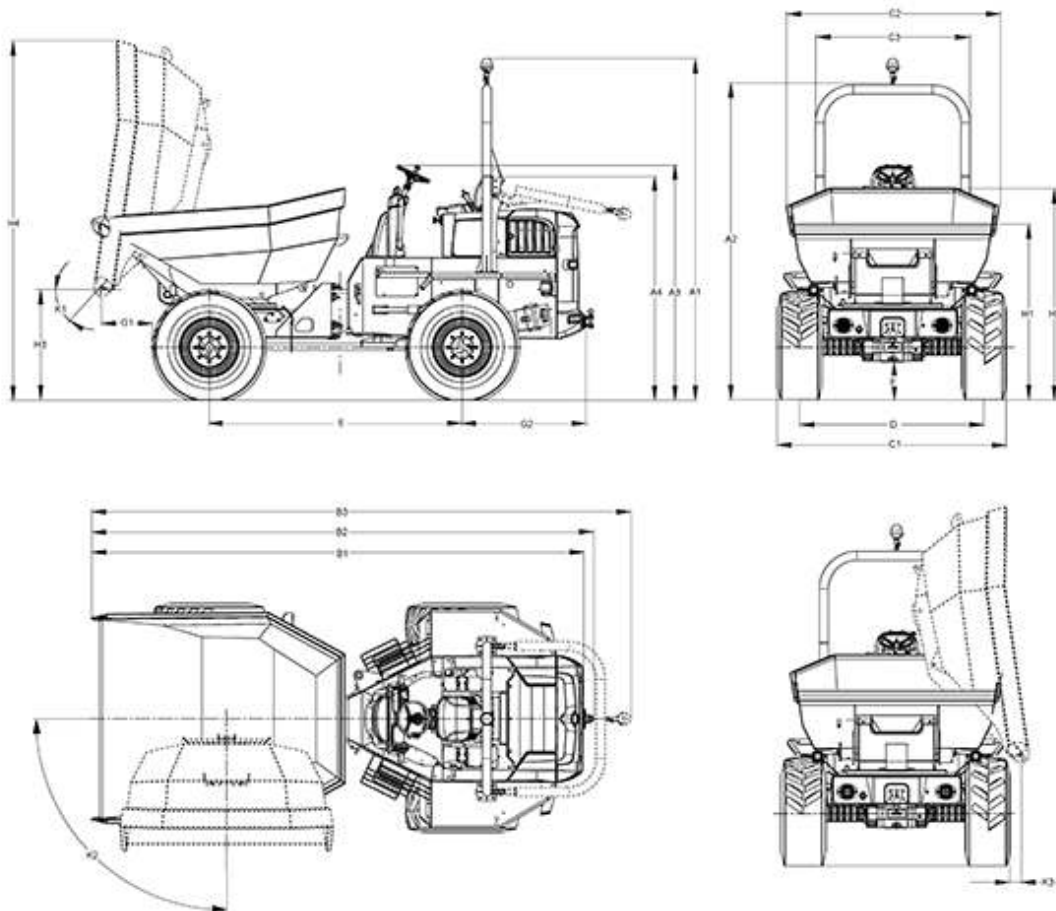

| | | |
|----|--------------------------------|----------|
| C1 | Overall width | 2,250 mm |
| C2 | Skip width swivel skip | 2,091 mm |
| D | Width | 1,810 mm |
| F | Ground clearance | 369 mm |
| H2 | Skip height | 2,075 mm |
| H4 | Skip height tilted | 3,524 mm |
| K1 | Tip-out angle | 48 ° |
| A1 | Height total (ROPS) | 3,348 mm |
| A3 | Height tilted ROPS | 2,299 mm |
| B2 | Length | 4,934 mm |
| E | Wheelbase | 2,485 mm |
| G2 | Rear overhang | 1,192 mm |
| G1 | Distance Mulde gekippt und Rad | 842 mm |



**WACKER
NEUSON**

Please note

that product availability can vary from country to country. It is possible that information / products may not be available in your country. More detailed information on engine power can be found in the operator's manual; the stated power may vary due to specific operating conditions.

Subject to alterations and errors excepted. Applicable also to illustrations.

Copyright © 2015 Wacker Neuson SE.